

MURAKKAB MANTIQIY CHIZMALAR TUZISH VA ULARNING NATIJASINI TEKSHIRISHDA MultiMedia Logic DASTURIDAN FOYDALANISH

Ш.Р.Бобобеков– ЖДПИ ўқитувчиси

E-mail: sh.r.bobobekov@mail.ru, tel: (93)-540-41-25

Аннотасија

Ushbu maqolada murakkab mantiqiy sxemalarini tuzish va ularning natijasini tekshirishda “MultiMedia Logic” mantiqiy dastur imkoniyati, informatika va axborot texnologiyalari fani mashg’ulotlarida o’quvchilarga o’rgatishning avzalliklari bayon etilgan.

Kalit so‘zlar: mantiq, ventil, simulyator, inkor, va, yoki, xor.

Аннотация

В этой статье описаны преимущества логического программирования “MultiMedia Logic” при построении сложных логических схем и их результаты, преимущества обучения студентов информатике и информационным технологиям.

Ключевые слова: логика, вентил, симулятор, отрицание и, или, xor.

Annotation

This article describes the advantages of “MultiMedia Logic” logic programming in the construction of complex logic circuits and their results, the advantages of teaching students in computer science and information technology.



Key words: logic, ventil, simulator, not, and, or, xor.

Hozirgi kunda murakkab mantiq masalalarning sxemalarini loyihalashtirishda ko‘plab mantiqiy dasturlar yaratilgan. Shunday mantiqiy dasturlardan biri *MultiMedia Logic* dasturidir. Ushbu dasturdan ta’lim jarajonida ham foydalanish samarali hisoblanadi. Ya’ni samaraliligishundaki, murakkab mantiqiy sxemalarini tuzish va ularning natijasini tekshirish imkoni mavjudligidir. Bu esa mantiqiy bilimlarni tekshirish va mustahkamlab borish imkonini beradi. Endi ushbu mantiqiy dastur bilan batafsil tanishib chiqamiz.

Multimedia Logic (MMLLogic) - bu har qanday murakkablikdagi mantiqiy sxemalarni va kompyuter qurilmalarini simulyatsiya qilish uchun ishlatilishi

mumkin bo‘lgan dasturdir. Uning muallifi George Mills bo‘lib, dasturni Softronix firma sayti (<https://www.softronix.com>) ga joylashtirgan [1].

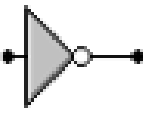
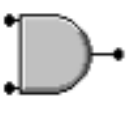
Dasturning halqaro inglizchava ГОСТ 2.743-91- ruscha interfeyslar mavjud. Bundan tashqari ventillarining ko‘rinishida ham farq qiladi. Siz o‘zingizga qulay versiyada ishlayishingiz mumkin.

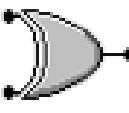
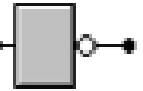
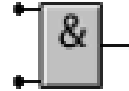
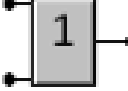
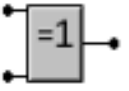
Versiyasi	inkor	va (and)	yoki (or)	xor
Halqaro				
ГОСТ 2.743-91				

MultiMedia Logic dasturini o‘rnatish oddiy dasturlarni o‘rnatish kabi amalga oshiriladi, agar siz dayo‘q bo‘lsa uni <http://www.softronix.com/manzildanbepulolishingiz> mumkin.

Agar siz ruscha interfeysiga qulay bo‘lsa, u holda Mmlogic_rus2.exe faylini ishga tushiring:

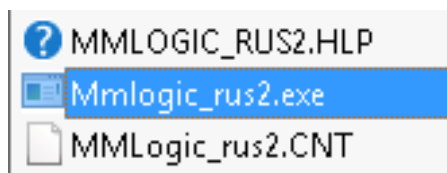

Natijada quyidagi dastur interfeysi oynahosil bo‘ladi:

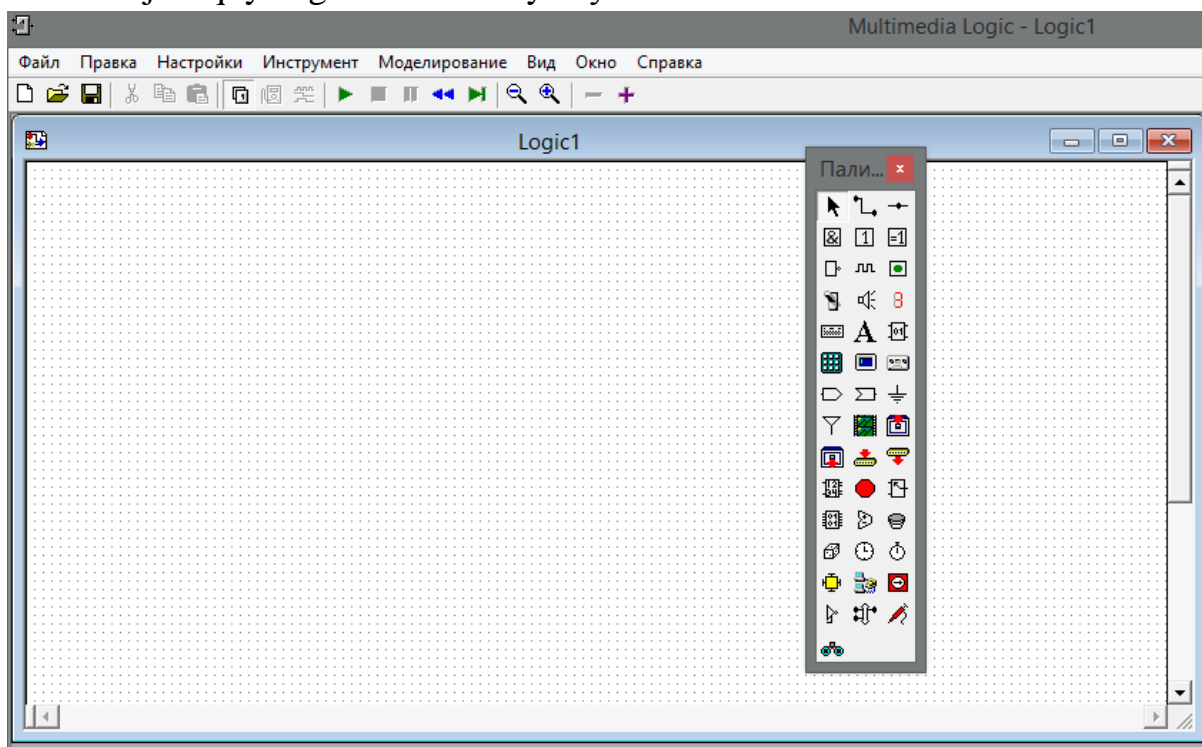

Keyin Multimedia Logic oynasining to‘liq ekranini bosib (oynaning o‘ng tomonida “Пали...” instrumentlar oynasi mavjud). Agar Palitrako‘rinmasa, oynaning yuqori qismidagi “Моделирование” menyusidan “Рисование схемы” buyrug‘ini tanlang.

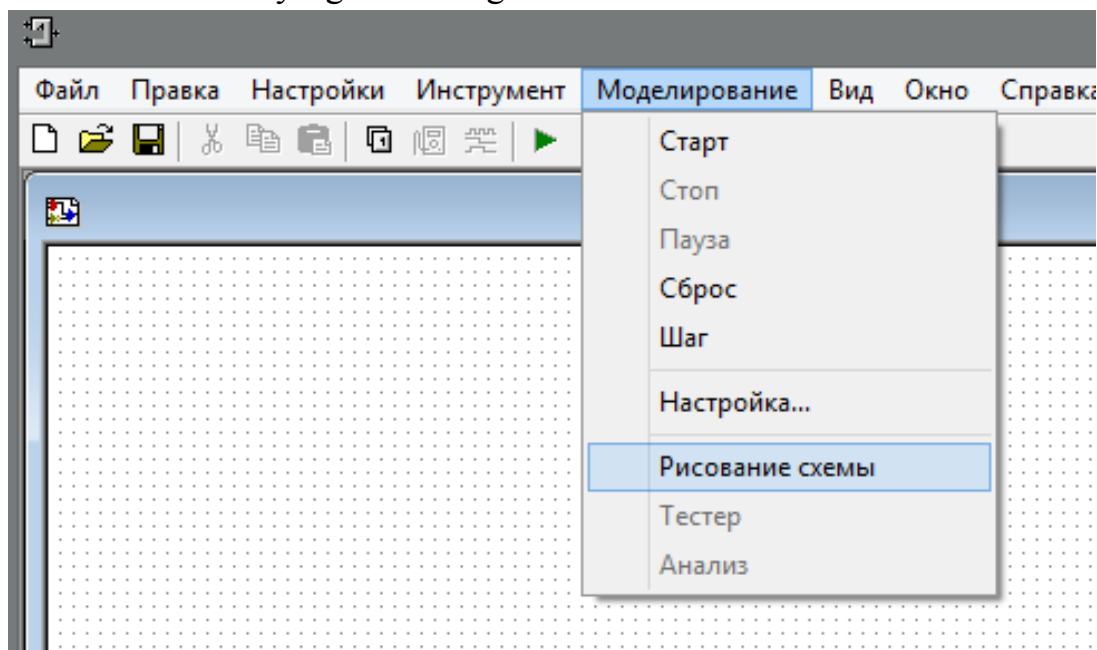

- Sichqonchadan foydalanib, palitrani oynaning o‘ng tomoniga, sarlavhasini ko‘rsatib, uni o‘zingizga qulay joyga sudrab o‘tkazing.

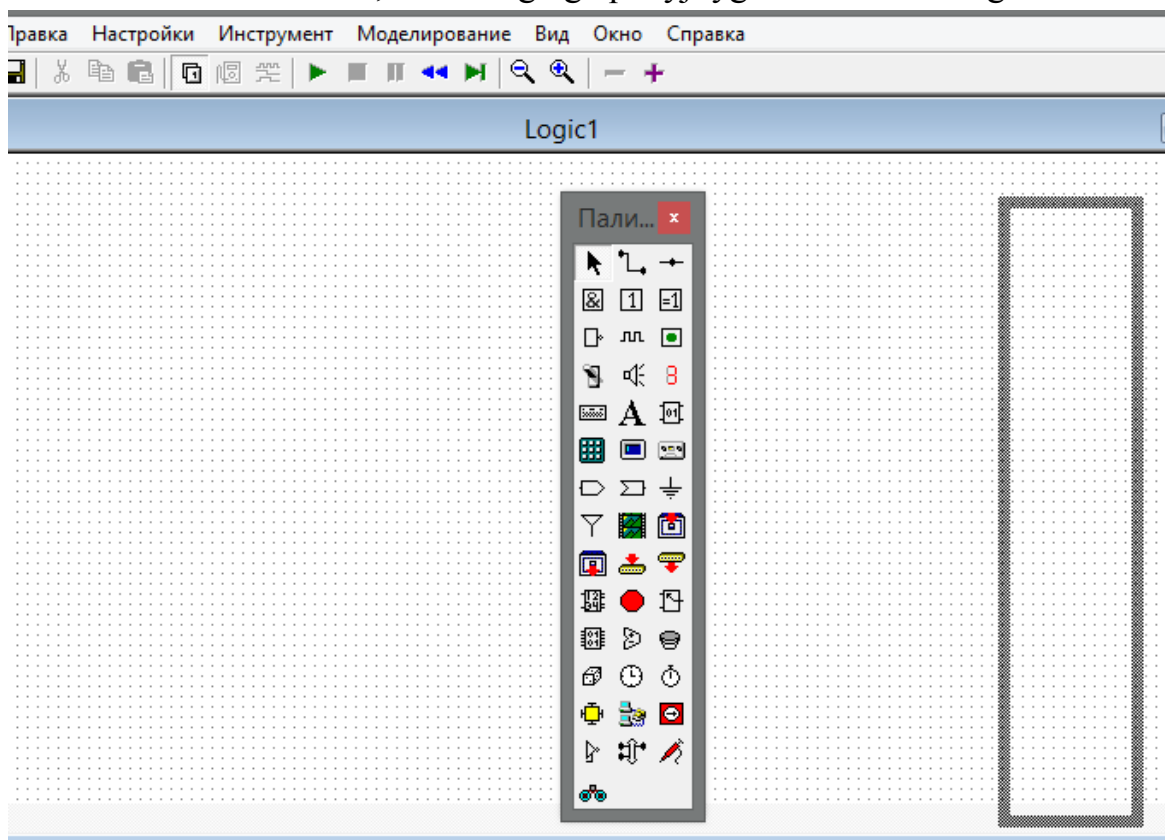

Endi simulyator damantiqiy mallarning chizma chizish va tekshirishni ko‘rib chiqamiz.

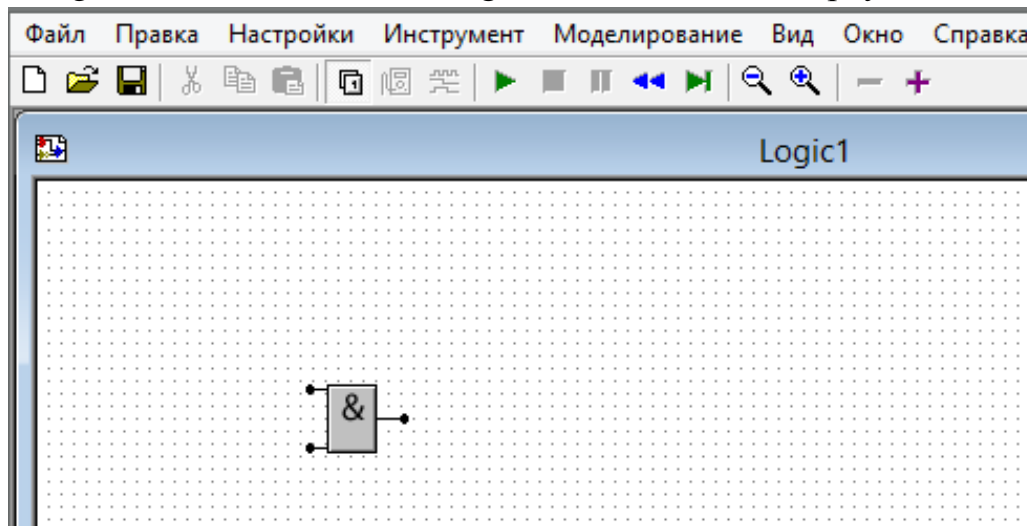

Misol uchun, A va B elementlar ustida quyidagi ketma-ketliklarni amalga oshiramiz:

- Palitrani ikkinchi qatoridagi birinchi belgib o'lgan "И" (VA) element belgini bosib va kursor boshqachabelgiga (+) o'zgaradi.
- "И" elementni ish stolining ixtiyoriy joyiga sichqonchani o'tkazib va chap tugmachani bosib va "И" element rasmchasi paydo bo'ladi. Agar tugmani bir necha marta bossangiz bir nechta rasmchalar paydo bo'ladi.

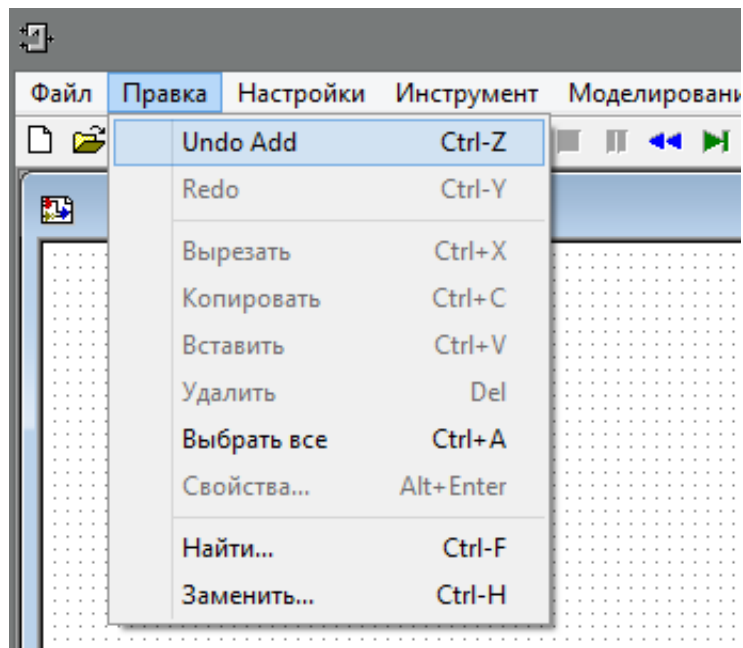

- Palitrani yuqori qatoridagi birinchi belgib o'lgan strelka belgini bosib.
- "И" element rasmchasi belgilang va uni ekran bo'ylab qulay joyga suring. Agar siz bog'lanishlarning zanglashiga olib keladigan qisminin o'tg'ri joyga qo'ysangiz, uni strelka yordamida tanlab, kerakli joyga tortib olishingiz mumkin.
- Klaviatura dagi "Delete" tugmachasi bosib va "И" element rasmchasi yo'qoladi. Agar siz tasodifan kerak bo'lmagan instrumentni chizib qo'ysangiz, uni tanlab o'chirishingiz mumkin.
- Sichqonchani oynaning yuqori qismidagi "Правка" menyusidan "Undo Add" so'zini bosib va "И" element rasmchasi yanapaydo bo'ladi. Agar biron bir xato qilsangiz, uni hardimor qaytarishingiz mumkin.



- Palitraning to'rtinchi qatoridagi birinchi belgi  bo'lgan kommutator uchun belgi (выключатель) nibosining.
- Sichqonchani oynaning chap tomoniga suring va tugmani ikki marta bosing, bundak kommutatorning ikki tana xasiyaratiladi.
- Palitraning uchinchi qatoridagi uchinchi belgi bo'lgan  yorug'lik chiqaradigan diod (Лампочка) uchun belgi nibosining.
- Sichqonchani oynaning o'ng tomoniga suring va tugmani bir marta bosing
- Endi ekran quyidagicha ko'rinish kerak:

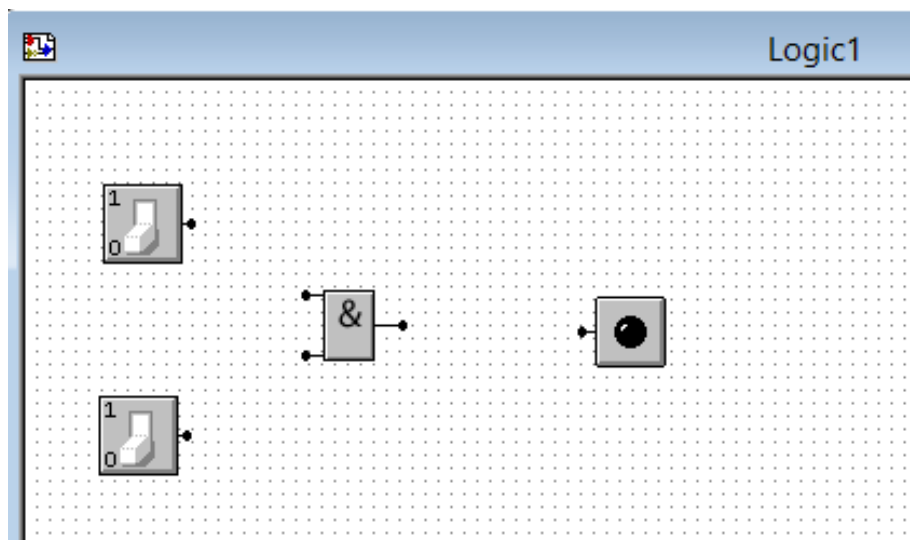

- Elementlarning chap va o'ng tomonlarda qoranuqtaborligiga e'tibor berib, bular ulanish nuqtalari. Har birkommutatorning o'ng tomonida bitta ulanish nuqta tasibor,

har birlampochkaning chap tomonidabittadanva“И” element chap tomonidaikkitavao‘ngtomonidabittadanmavjud.

Qismlarnibir-birigaulash

- Palitraniyuqoriqatoridagiikkinchibelgisi  bo‘lganulagich (Соединение) belginibosingvakursorshakliniboshqachabelgisigao‘zgartiradi.
- Belginiyuqoridagiva chap tugmachaningo‘ngtomonidagiulanishnuqtasigadiqqatbilanqarating.
- Sichqonchani chap tugmachasinibosingvaulagichni “И” elementining chap tomonidagiyuqoriulanishnuqtasigaolib boring vatugmani qo‘yibuboring.

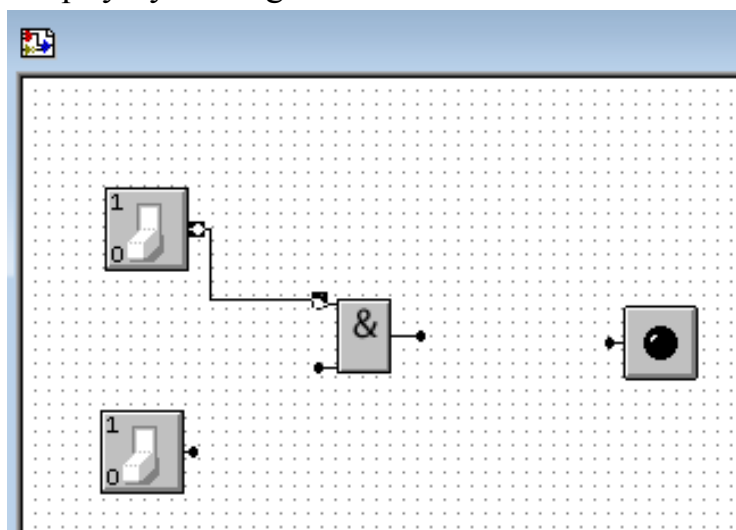

- Agar sizulanishnuqtasidagiulanishnuqtasini o‘tkazibuborsangiz, ulanishuchunhechnarsayo‘qxatodegankichikbiroynaochiladi. OK nibosingvayanauribko‘rishingiz mumkin.
 - Agar sizulanishnuqtasini “И” elementigao‘tkazibuborsangiz, ulanishyo‘qoladivauniboshqatdanchizishgaharakatqiling.
 - Ulagichlarnixuddishunday, pastkiva “И” elementining chap tomonidagipastkiulanishnuqtasigaulang.
 - Shungao‘xshashtarzda “И” elementningo‘ngtomonidagiulanishnuqtasigaxuddishutarzdaulang.
 - Endi “И” element pastkitomonidagiviklyuchatekningo‘ngtomonidagiulanishnuqtasigaqo‘shing.
- Bittaulanishnuqtasigaikkitaulagichniulashingiz mumkinligigae’tiborbering. Natijaquyidagichako‘rinishgaegabo‘ladi:

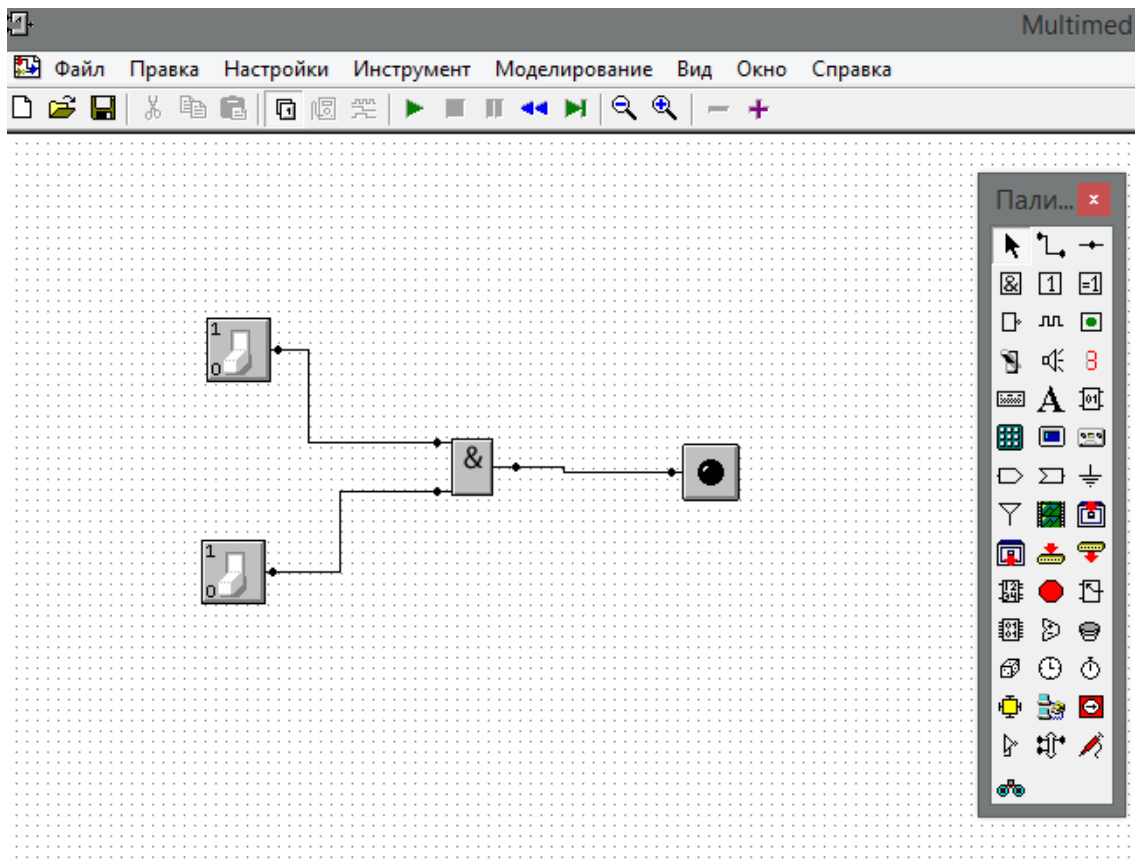

- Agar biron-birmuammobo‘lsa, elementlarniyoki ulagichlarni yo‘qqilish va almashtirish orqali ularni tuzating. Ulagichni tanlayotganda, uning oxiriga e‘tibor qilishingiz kerak, agar siz “И” elementida o‘ng tomonga ulanish nuqtasiga ishora qilsangiz, ikkala ulagichni ham tanlaysiz.
- Elementlarni surib ko‘ring va ulagichlar qanday ulanganligiga e‘tibor bering. Виключатель (ВЫКЛЮЧАТЕЛЬ) yordamida tekshirish.
- Ekranning yuqorisidagi to‘rtinchi guruhning birinchi belgisibo‘lganyashil uch burchakni  bosning.
- Ikki ta viklyuchatellarni bosning va ularni yoqing, natijada lampayonishi yoki o‘chishi niko‘rasiz.

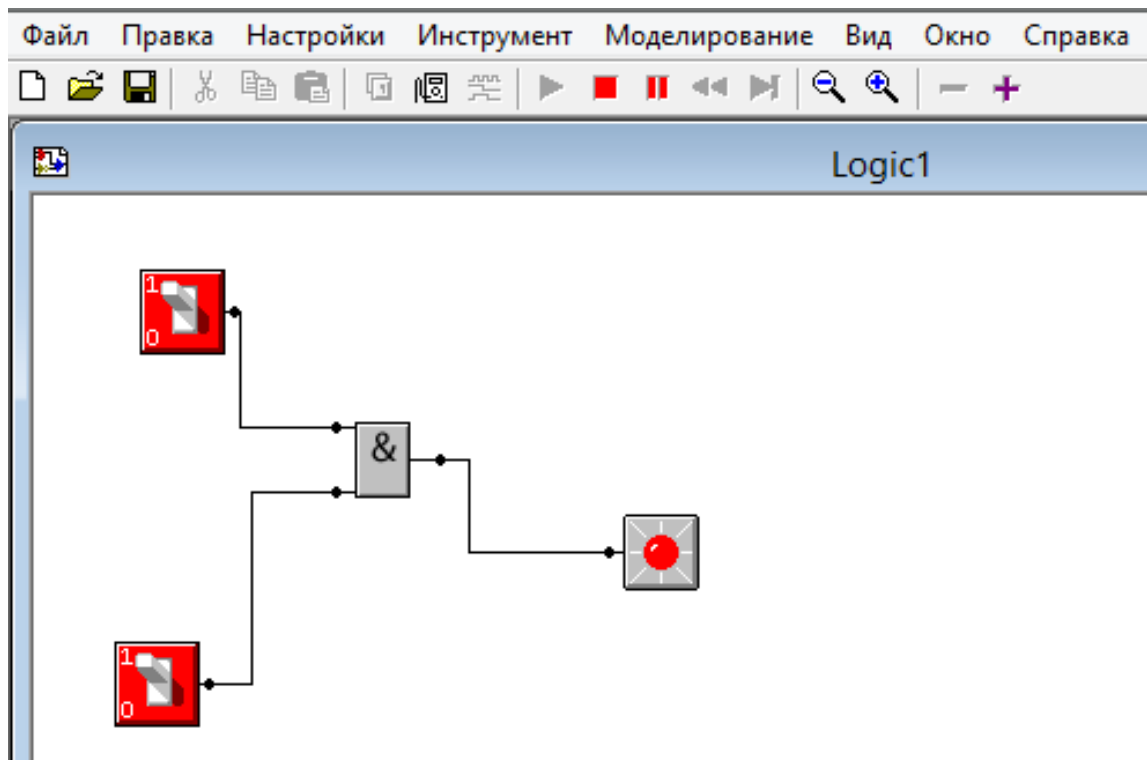

- “И” element to‘g‘riishlayotganiga ishonch hosil qilish uchun ularni bir nechamart ayoqing va o‘chiring.
 - Natijalarni ikkilikdagi chiqishini solishtiring.
 - Oynaning yuqori qismidagi to‘rtinchi guruh piktogrammasidagi yashil uchbur chakyonidagi qizil kvadrat ustiga bosing va simulyator to‘xtaydi.
- “И” elementni o‘zgartirish.
- Sichqonchako‘rsatkichi bilan “И” elementrasimchanibelgilang va o‘ng tugmachani bosing. Menyudaxususiyat (свойства) nitanlang va yoriqli oyna ochiladi:

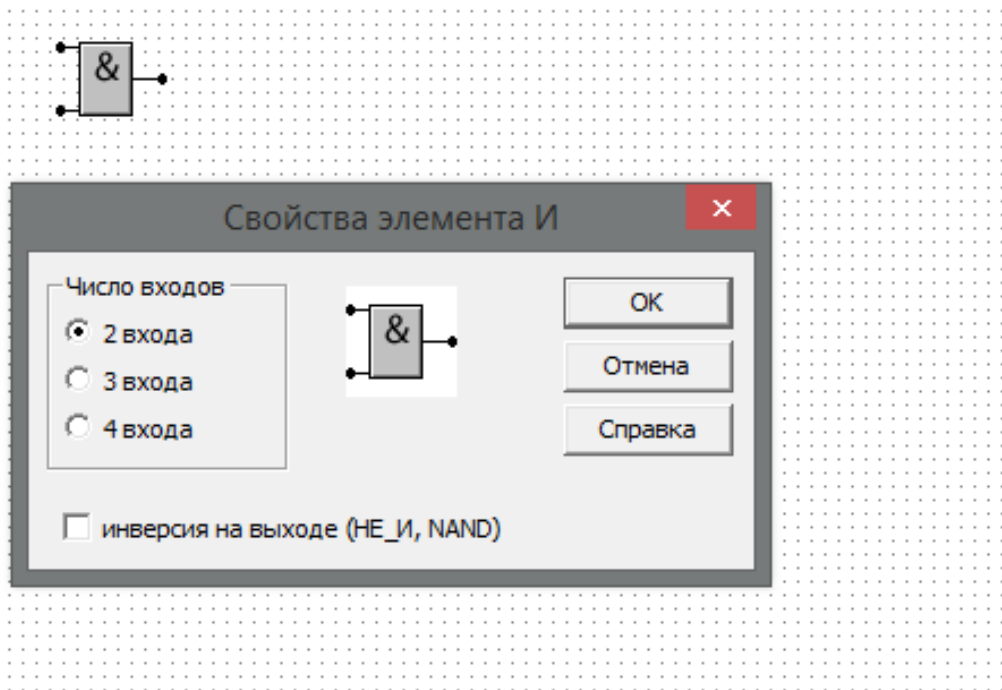

- Oynaning chap tomonida elementgakirishni 3 va 4 taga o'zgartirishimkoniniberadi, masalan "3 входы" tanlasak "И" element rasimchasiningoldida 3 ta ulash nuqtasipaydobo'ladi. Agar inkoramaliniqo'moqchibo'sangiz "инверсиянавыходе" gabelqiq'ying.

Xulosaqilibaytganda, murakkab mantiq masalalarningsxemalariniloixalashtirishdaushbu mantiqiy dasturdan foydalanish hozirgikundagiqulayvasamaralihisoblanadi.

Shuninguchun ham o'quvchilarigainformatikavaaxborot texnologiyalaridarslarida *MultiMedia Logic* dasturimkoniyatlaridanfoydalanibmantiqiysxemalarnituzishvauningnatijasinitekshirishbo'yichakengroqbilimvako'nikmaberishmaqsadgamuvo fiqhisoblanadi.

Foydalanilgan adabiyotlar

1. <https://www.kpolyakov.spb.ru/school/mmlogic.htm>
2. <https://www.softronix.com>